

S38

S38-S

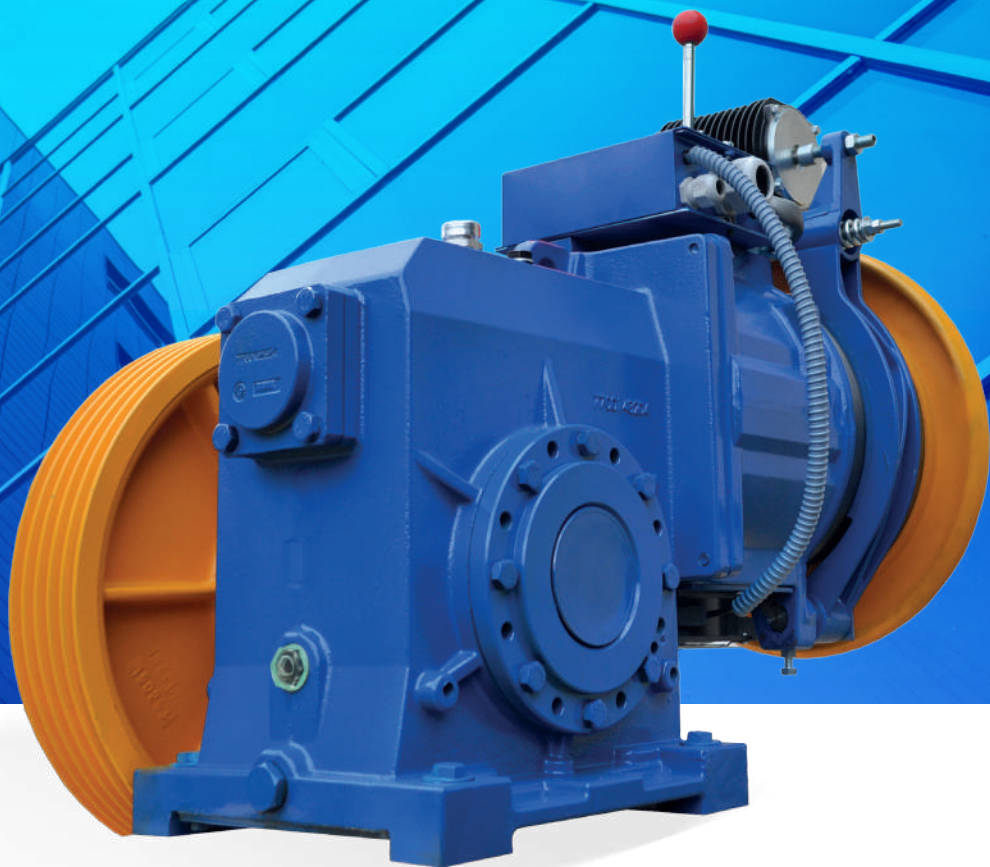

DATA

DATOS
DATI
ANGABI
DONNEES

S38

S38-S

Max. static load
Máxima carga estática
Carico statico max
Statische Höchstlast
Charge statique maxi

kg 3000

kg 3300

Ratios

Reducciones
Rapporti
Übersetzungen
Rapports

1/71 1/55 1/45 2/57

1/71 1/55 1/45 2/57

Powers range at 4/16 poles

Escala potencias con 4/16 polos
Gamma potenze a 4/16 poli
Leistungsbereich für 4/16 Polen
Gamme puissances 4/16 pôles

4.0 > 5.5 kW sync

4.0 > 5.5 kW sync

Powers range at 6/24 poles

Escala potencias con 6/24 polos
Gamma potenze a 6/24 poli
Leistungsbereich für 6/24 Polen
Gamme puissances 6/24 pôles

2.9 > 3.3 kW sync

2.9 > 3.3 kW sync

Powers range at VVVF at 4 poles

Escala potencias VVVF con 4 polos
Gamma potenze VVVF a 4 poli
Leistungsbereich VVVF für 4 Polen
Gamme puissances VVVF 4 pôles

3.3 > 7.3 kW syncC

3.3 > 7.3 kW syncC

Moment of inertia J

Momento de inercia J
Momento d'inerzia J
Trägheitsmoment J
Momente d'inertie J

kgm² 0.010

kgm² 0.010

Oil capacity

Capacidad aceite
Capacità olio
Ölmenge
Capacité huile

3,5 l

3,5 l

DRIM

S38 | S38-S



S38 4/16 50hz				Speed Velocidad Velocità Geschw. Vitesse	Ratio Reducción Rapporto Übersetz. Rapport	Sheave Polea Puleggia Treibsch. Poulie
Kw >	4.0	4.9	5.5	m/sec		Ømm
448				0.39	1/71	360
404				0.44	1/71	400
404	423			0.51	1/55	360
336				0.53	1/71	480
363	443			0.57	1/55	400
311				0.57	1/71	520
288				0.61	1/71	560
360	439	488		0.62	1/45	360
268				0.66	1/71	600
302	369			0.68	1/55	480
323	395	439		0.69	1/45	400
279	341			0.74	1/55	520
230				0.77	1/71	700
259	316			0.79	1/55	560
270	329	366		0.83	1/45	480
241	295			0.85	1/55	600
249	304	338		0.90	1/45	520
231	282	314		0.97	1/45	560
316	386	429		1.00	2/57	360
207	253			1.00	1/55	700
216	263	293		1.04	1/45	600
284	347	386		1.10	2/57	400
184	225	250		1.22	1/45	700
236	288	321		1.32	2/57	480
218	266	296		1.43	2/57	520
203	248	276		1.54	2/57	560
189	231	257		1.65	2/57	600
162	198	220		1.93	2/57	700

S38 VVVF 50hz										Speed Velocidad Velocità Geschw. Vitesse	Ratio Reducción Rapporto Übersetz. Rapport	Sheave Polea Puleggia Treibsch. Poulie
Kw >	3.3	3.7	4	4.8	5.5	5.9	6.2	6.6	7.3	m/sec		Ømm
414	450	490								0.39	1/71	360
383	412	443								0.44	1/71	400
432	465	501	539	576						0.51	1/55	360
318	342	368								0.53	1/71	480
389	419	451	485	518						0.57	1/55	400
293	316	340								0.57	1/71	520
270	292	315								0.61	1/71	560
382	411	442	475	511	550					0.62	1/45	360
254	273	293								0.66	1/71	600
317	341	367	394	424						0.68	1/55	480
342	367	395	425	457	491					0.69	1/45	400
293	315	339	364	392						0.74	1/55	520
217	234	251								0.77	1/71	700
271	292	314	338	363						0.79	1/55	560
285	306	329	354	381	410					0.83	1/45	480
265	285	307	330							0.85	1/55	600
263	283	304	327	352	378					0.90	1/45	520
245	263	283	304	327	351					0.97	1/45	560
249	268	288	310	333	359	386	415	446		1.00	2/57	360
212	228	245	263	283						1.00	1/55	700
228	245	264	284	305	328					1.04	1/45	600
242	260	279	300	323	347	374	402	432		1.10	2/57	400
195	209	225	242	260	280					1.22	1/45	700
201	216	232	250	269	289	310	334	359		1.32	2/57	480
185	199	215	230	248	266	286	308	331		1.43	2/57	520
173	186	200	215	231	248	267	287	309		1.54	2/57	560
161	173	186	200	215	231	249	268	288		1.65	2/57	600
137	148	159	171	184	198	213	229	246		1.93	2/57	700

4/16 poles				
Kw SYNC	3.5	4.0	4.9	5.5
A	382	382	382	382/400

VVVF	
Kw SYNC	3.3/7.3
A	382

6/24 poles		
Kw SYNC	2.9	3.3
A	382	400

Out of balance load in kg with shaft efficiency = 0.8
 Carga descompensada en kg. con rendimiento del hueco = 0.8
 Differenza di tiro in kg con rendimento del vano = 0.8
 Zugkräfte in kg mit Schachtwirkungsgrad = 0.8
 Force de traction en kg avec rendement de la gaine = 0.8

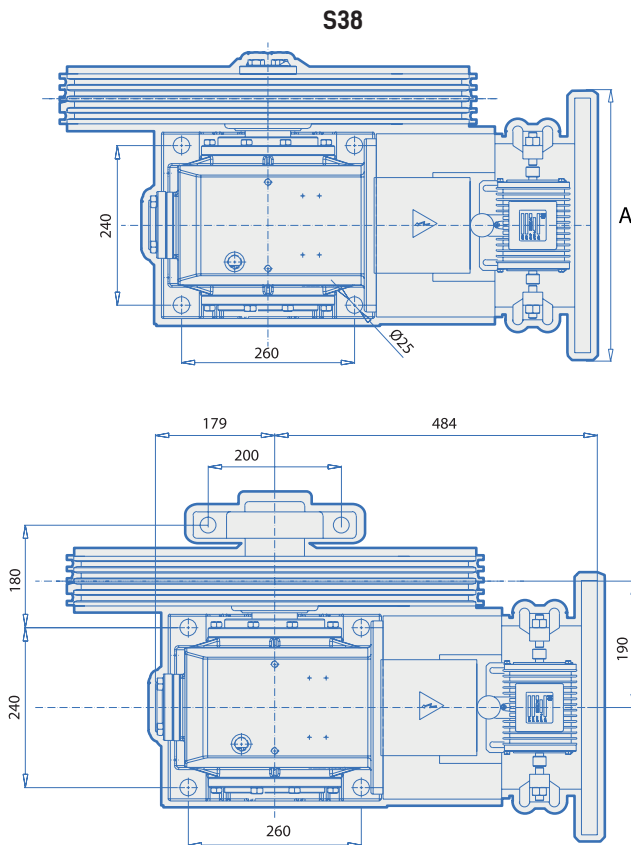

S38-S

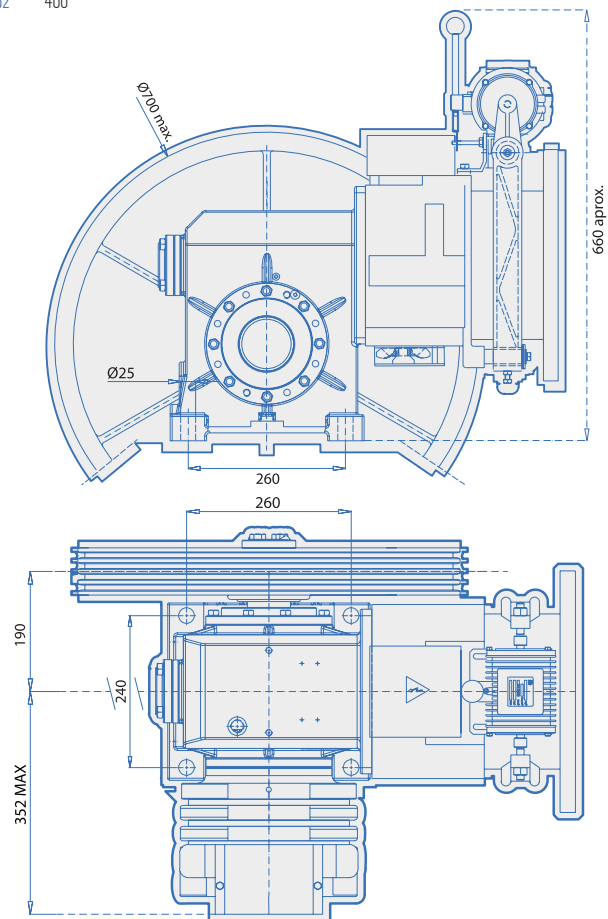

S38 Security Brake DF model